

Table of Contents

1.0	Introduction	Page 2	6.0	Changing Settings	20
2.0	Features	2	7.0	Target Recall of Last Trip Data	21
2.1	DC Current Sensing	3	8.0	Normal Operation	22
2.2	UV Overload trip	3	9.0	Testing & Calibrating – Transducer Input	22
2.3	Ground Fault	4	9.1	Step 1: Commission the Trip Unit	23
2.4	16 Character Display	4	9.2	Step 2: Verify Transducer Installation	23
2.5	Last Trip Data	4	9.3	Step 3: Defeat Reverse Current	24
2.6	Current Transducers	5	9.4	Step 4: Calibrate the Transducers	24
2.7	Breaker Tripping	5	9.5	Step 5: Defeat Ground Fault (GF)	25
2.8	Alarm Relay	6	9.6	Step 6: Verify Pick-Up & Calibration	25
2.9	Displayed Trip Unit Error Messages	6	9.7	Step 7: Primary Injection Tests	25
2.10	Battery	7	9.8	Step 8: Reverse Current Testing	25
3.0	Options	8	9.9	Step 9: Erase Last Trip Data	26
3.1	External Connections	8	10.0	Testing – Shunt Input	26
3.2	Optional Connections	8	11.0	Ratings	27
3.3	Communications Option	9	12.0	Warranty	27
3.4	Shunt Input Option	9	13.0	Time-Current Curve	27
3.5	Quick-Trip™ System Option	10	13.1	LT Trip Time	28
4.0	Security Key	11	13.2	ST Trip Time	28
5.0	Commissioning	11	13.3	GF Trip Time	29
5.1	Power-Up the Trip Unit	12	13.4	Overload TCC	31
5.2	Security Key During Commissioning	12	13.5	Reverse & GF TCC	33
5.3	Transducer / Shunt Input Select	12	13.6	Quick-Trip™ GF and Instantaneous	35
5.4	Transducer / Shunt Rating	13	14.0	Typical Wiring Diagrams	
5.5	Long-Time Pick-Up Setting	13	14.1	Using Actuator	37
5.6	Long-Time Delay Setting	13	14.2	Using Electro-Mechanical Trip Relay	39
5.7	LT Thermal Memory	14	14.3	Using Solid-State Trip Relay	41
5.8	Short-Time Pick-Up Setting	14	14.4	Using Shunt Input	43
5.9	Short-Time Delay Setting	14	14.5	Communications Connections	45
5.10	Short-Time I ² T	15			
5.11	Instantaneous Pick-Up Setting	15			
5.12	Ground Fault Pick-Up Setting	15			
5.13	Ground Fault % Restraint	15			
5.14	Ground Fault Delay Setting	16			
5.15	Ground Fault I ² T	16			
5.16	Reverse Current Pick-Up	16			
5.17	Reverse Current Delay Setting	16			
5.18	Reverse Current I ² T	17			
5.19	Quick-Trip™ Instantaneous Pick-Up	17			
5.20	Quick-Trip™ Ground Fault Pick-Up	17			
5.21	COM Address (Communications)	18			
5.22	Reply Delay	18			
5.23	Alarm on COM	19			
5.24	Alarm on Overload	19			
5.25	Alarm on Trip	19			
5.26	Alarm on ERROR	19			
5.27	Exit Procedure	20			

Firmware Revision: 5.00, Revision 0

1.0 Introduction

The **ZERO-Hertz** is a state of the art, micro-controller based trip unit intended for use on one and two pole DC circuit breakers in voltage classes up to 1,000 volts.

As an option, the **ZERO-Hertz** trip unit can also be applied as a panel mounted protective relay, which utilizes the signal from a DC shunt.

The **ZERO-Hertz** is a digital trip unit using a micro-controller and a 16-character liquid crystal display (LCD).

The trip unit provides over-current, as well as short-time and instantaneous fault protection. The trip unit also offers reverse current and ground fault protective functions as user selectable options.

Quick-Trip™ arc flash hazard reduction is available as an option.

A user configurable alarm relay is a standard feature on the **ZERO-Hertz**. The alarm relay contains a form-C contact.

The trip unit requires external power to operate. External power can be applied to the trip unit from one of two sources:

- 1) By connecting to the positive (+) and negative (-) poles of a two pole DC breaker in service on a circuit between 90-340 volts DC.
- 2) By connecting to the breaker control power. The control power must be between 90-340 volts DC or 75-265 volts AC.

The trip unit installation kit also includes a two-pole fuse block with two Bussmann type KLM-5, 500Vdc current limiting fuses. The power wiring to the trip unit should always be protected with these fuses.

2.0 Features

The **ZERO-Hertz** offers the following features:

- a) Unique current sensing method permits testing of the transducer inputs of the trip unit on a DC as well as a AC high current test set (on most breakers).
- b) Displays last trip data including the current at the time of trip.
- c) All settings are made directly in amps or in seconds.
- d) A security system reduces the risk of unauthorized tampering with the trip unit's settings.
- e) Ease of coordination is provided with settings that are made in extremely small increments.
- f) Plug-in wiring reduces the installation time and eliminates wiring errors.
- g) 16-character alphanumeric display with backlight.
- h) Small package.
- Quick-Trip™ arc flash hazard reduction is available as an option.

The **ZERO-Hertz** also incorporates **SELF TEST OK** features, which continually monitor the status of the trip unit. The green LED on the face of the trip unit provides a visual indication that the trip unit is operating properly.

SELF TEST OK features include:

- 1.) Watch-dog timer and check-sum monitoring to ensure the micro-controller is functioning properly.
- 2.) Actuator and "+" and "-" pole transducer monitoring to ensure that these vital components are properly connected.

As part of the manufacturing quality control, each trip unit is "burned in" under load at 120°F.

2.1 DC Current Sensing

The **ZERO-Hertz** uses a micro-controller to perform the DC current calculations and to implement the logic functions.

The trip unit determines the DC current by measuring the true RMS current of the circuit. The trip unit samples at a 0.521 milli-second rate during the sample period of 8.333 milliseconds. For each sample period, the micro-controller performs the RMS calculation by squaring the current samples, finding the average of the square values and then taking the square root of the average. This value is then multiplied by the transducer or shunt rating to arrive at the current in amps.

This method of current sensing provides an extremely accurate measurement of DC current when applied on a DC circuit. This method also provides an equally accurate measurement of true RMS AC current when applied on a 60 Hertz AC circuit. This enables the transducer inputs of the trip unit to be tested on a high current DC or a 60-Hertz AC test set (on most breakers) for Long-Time, Short-Time, Instantaneous, Ground Fault and Reverse Current trip functions.

When the trip unit is applied on a two-pole breaker and two transducers are being used, the RMS calculation is performed individually for each pole of the breaker.

2.2 UV Overload trip

The Under Voltage Overload (UV OL) trip function will produce a trip when the system voltage collapses during a low impedance fault. This is useful for those installations where the trip unit is powered by the system voltage.

Whenever the current is greater than two (2) times the LT Pick-Up setting and the trip unit power goes below the minimum required to operate the trip unit, a UV Overload trip is immediately initiated.

The user cannot turn off this feature.

2.3 Ground Fault

The ground fault feature of the **ZERO-Hertz** can only be implemented when two transducers are used with the trip unit, one on the positive (+) pole and one on the negative (-) pole of the breaker. The ground fault function is not available when using shunt input.

The trip unit measures the current of each pole individually and determines the ground current to be the difference between the absolute values of the current on the positive (+) and negative (-) poles measured in amps.

**** NOTE ****

The trip unit can detect how many transducers are properly connected to it. The trip unit will only implement ground fault protection when it detects two transducers.

The ground fault feature is not available when using the shunt input.

2.4 16-Character Display

A 16-character dot matrix liquid crystal display (LCD) is the interface between the trip unit and the user.

The dot matrix LCD is extremely versatile because it is capable of displaying not only numbers but also letters and symbols.

The LCD is used for the following purposes:

- 1) Entering the transducer or shunt input rating and making the pick-up and time delay settings with prompts from the display.
- 2) Displaying on demand, all trip unit settings.
- 3) Displaying on demand, the reason for the last trip and the current at the time of trip.
- 4) Continuously displaying the actual DC current on the circuit.

2.5 Last Trip Data

After a breaker trip, the trip unit will save the trip data in its non-volatile EEPROM memory. The last trip data can be recalled later. This data is written over with the data from the next trip event.

The last trip data consists of the type of trip (i.e., LT, ST, INST.....) and the associated DC current.

The abbreviations for the type of trip correspond to the following:

INST	Instantaneous
LT	Long Time
ST	Short Time
GF	Ground Fault
REVRS	Reverse Current
FORCED	A trip initiated from a remote PC using the communications option.
UV OL	Under Voltage Overload Trip
IQT	Quick-Trip Instantaneous
GFQT	Quick-Trip Ground Fault

A trip counter is also provided which indicates how many times the trip unit operated on each function.

The last trip data can be conveniently recalled at any time. See section 7.0, "Target Recall of Last Trip Data" for further information.

See section 9.9 for instructions on erasing the last trip data.

2.6 Current Transducers

The transducer(s) provided with the trip unit are specifically designed to operate **only** with the **ZERO-Hertz** trip unit.

The transducer determines the current in the conductor it is mounted on or near by measuring the magnetic field of the current in the conductor.

The user must calibrate the transducer to the current rating entered in the **ZERO-Hertz** trip unit (see Section 9.4).

For calibration, the transducer(s) must be installed on the breaker in the exact location shown in the installation manual for the specific circuit breaker.

Two different transducers are available for the **ZERO-Hertz** trip unit:

- 1.) Low-Range Transducer
- 2.) Hi-Range Transducer

The transducer(s) provided for a specific installation depend on:

- Breaker frame size
- The transducer rating required
- The geometry of the breaker where the transducer will be installed

2.7 Breaker Tripping

The trip unit is designed to trip different breaker types in different ways.

Breakers equipped with a shunt trip device will be tripped when the trip unit momentarily energizes an auxiliary trip relay (included with the retrofit kit), which in turn will energize the shunt trip device on the breaker.

The auxiliary trip relay may be either an electro-mechanical relay (Figure 14.2) or a solid-state relay (Figure 14.3).

The contacts of the auxiliary trip relay are capable of “making” but not “breaking” the shunt trip current. The contacts must be wired in series with a breaker auxiliary contact, which will “break” the shunt trip current when the breaker opens.

Breakers equipped only with the original electro-mechanical tripping devices will be tripped with a magnetically latched actuator included in the retrofit kit. The magnetically latched actuator can be a manual reset type or a mechanical auto-reset type.

The trip unit discharges an internal capacitor to trip the actuator or momentarily energize the auxiliary trip relay.

2.8 Alarm Relay

The **ZERO-Hertz** contains a configurable alarm relay with a Form-C contact. The contact is rated:

- 5 amps at 30 VDC
- 5 amps at 125 VAC

In normal operation, the alarm relay is in “FAIL-SAFE” mode. When the trip unit is not in service (control power is NOT applied) the alarm relay is in the “ALARM” state.

When control power is applied to the trip unit, the alarm relay will be energized and change to the “NORMAL” state. If the trip unit loses control power, the alarm relay will change to the “ALARM” state.

The alarm relay can also be configured, during commissioning, to “ALARM” under certain conditions. The configurable ON/OFF alarm states include:

- Alarm on Overload
- Alarm on Trip
- Alarm on Trip Unit Error
- Alarm through Communications (used with MODBUS communications)

The alarm relay is reset for the following alarm conditions (if enabled) as follows:

- Power Loss:
Automatically resets with restoration of control power.
- Alarm on Overload:
Automatically resets when overload is gone.
- Alarm on Trip:
Push the REVIEW push button to reset.
- Alarm on Trip Unit Error:
Automatically resets when error is corrected.
- Alarm on Communication Error:
Automatically resets when error is corrected.

2.9 Displayed Trip Unit Error Messages

If the **ZERO-Hertz** detects an error, one of the following will be displayed:

A/D ERROR

An out of range error with the analog-to-digital converter is detected in the trip unit.

CHECK XDUCERS

Both transducers are disconnected from the trip unit.

MEMORY ERROR

An error with the firmware code in the trip unit memory was determined by failure of the memory checksum to equal a known value.

NO ACTUATOR

Loss of continuity in the trip circuit was detected due to a broken or disconnected wire going to the actuator or trip relay coil or an open circuit in the actuator or relay coil.

The **SELF TEST OK** LED on the front of the trip unit is turned **OFF** and the trip unit does not provide protection until the error is corrected.

The alarm relay will be in the alarm state if it is configured to “Alarm on Trip Unit Error” until the error is corrected.

2.10 Battery

A 9-volt, 1200 mAh, long life, lithium/manganese dioxide battery is used in the trip unit. This battery has less than 2 grams of lithium. There are no restrictions on transport and no special methods of disposal required with this battery.

The battery is designed to provide two functions:

- 1) Allow the user to commission (program) the trip unit without control power.
- 2) Allow the user to recall the last trip data even if there is no control power.

Press the **REVIEW** push button to turn on the trip unit under battery power.

When on battery power, the trip unit will automatically turn off 30 seconds after the last push button is pressed to conserve battery energy.

**** NOTE ****

The battery is **NOT** involved in the protective functions of the trip unit. The trip unit will provide protection even if the battery is removed.

The battery is **NOT** required for the trip unit to maintain any of its memory including the user programmed pick-up and delay settings. All settings are stored in EEPROM memory.

Lithium battery ratings:

- Rated shelf life of ten-years
- 750mAh capacity for Energizer LA522
- 1200mAh capacity for Ultralife U9VL-J (Allows the review of last trip data and settings over 1500 times on battery power only)

To gain access to the battery, remove the nine screws securing the top cover plate on the trip unit.

**** IMPORTANT ****

For best performance, replace with one of the following 9-volt lithium battery:

Energizer LA522

Ultralife U9VL-J

McMaster-Carr # 7745K56

An alkaline type 9-volt battery may also be used with much shorter life.

The breaker must be removed from service before removing the top cover on the trip unit.

Observe proper polarity when replacing the battery.

3.0 Options

The **ZERO-Hertz** is available with the following options:

- Shunt input
- Communications
- Quick-Trip

3.1 External Connections

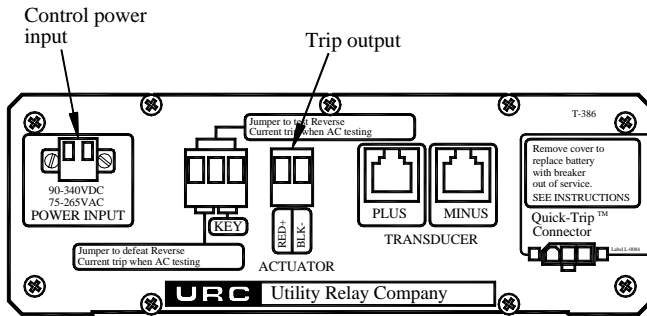

Top View of Trip Unit

The trip unit's external control power input is located on the left side of the top of the trip unit. For control power, the trip unit will accept:

- 90 - 340 VDC
- 75 - 265 VAC

The trip output for the actuator or trip relay is labeled ACTUATOR terminals, which are also located on the top of the trip unit.

3.2 Optional Connections

Depending on the specific model of the trip unit, the optional connections will be located on the top or bottom of the trip unit.

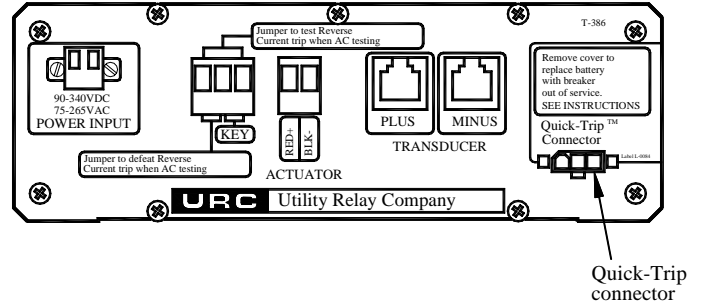

Option on top of ZERO-Hertz trip unit

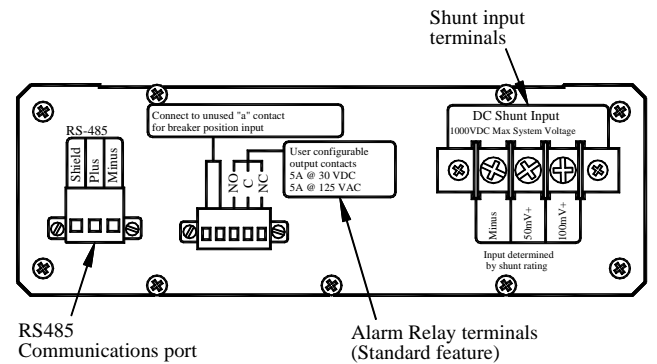

Options on bottom of ZERO-Hertz trip unit

The optional connectors are shown in the two views above. These include:

- Quick-Trip connector (right hand side, top view)
- RS-485 Communication port (left hand side, bottom view)
- Shunt input terminals (right hand side, bottom view)

The alarm relay terminals, shown in the middle, are included on every model of the **ZERO-Hertz** trip unit.

3.3 Communications Option

The Optional RS-485 communications port uses the industry standard MODBUS RTU protocol. Multiple trip units can be daisy-chained together using a single twisted pair wire.

Information monitored includes:

- DC current
- Last trip data
- Trip counter
- Alarm conditions
- Trip unit settings

The **ZERO-Hertz** also features remote programmability, which allows trip settings to be programmed remotely from a PC.

With the addition of URC's LCI (Local Communications Interface), **ZERO-Hertz** trip units can communicate directly across a local area network (LAN).

For **ZERO-Hertz** trip units equipped with the Communications option, consult the *AC-PRO+/ZERO-Hertz Communications Instruction Manual (PN: I-COMM)*.

3.4 Shunt Input Option

The shunt input allows signal input to the **ZERO-Hertz** directly from a DC metering shunt in the switchgear. The shunt input is used instead of the transducers as a means to measure the DC current.

During commissioning of the trip unit, the shunt input or the transducers are selected as the signal input for the trip unit. Section 5.0 details the procedure for commissioning a trip unit to use the shunt input.

The terminals on the bottom of the trip unit allow for direct connection to either a 50mV or 100mV DC metering shunt.

Maximum recommended operating system voltage is 1000 VDC. The internal isolation is 3750 VDC for 60 sec.

3.5 Quick-Trip™ System Option

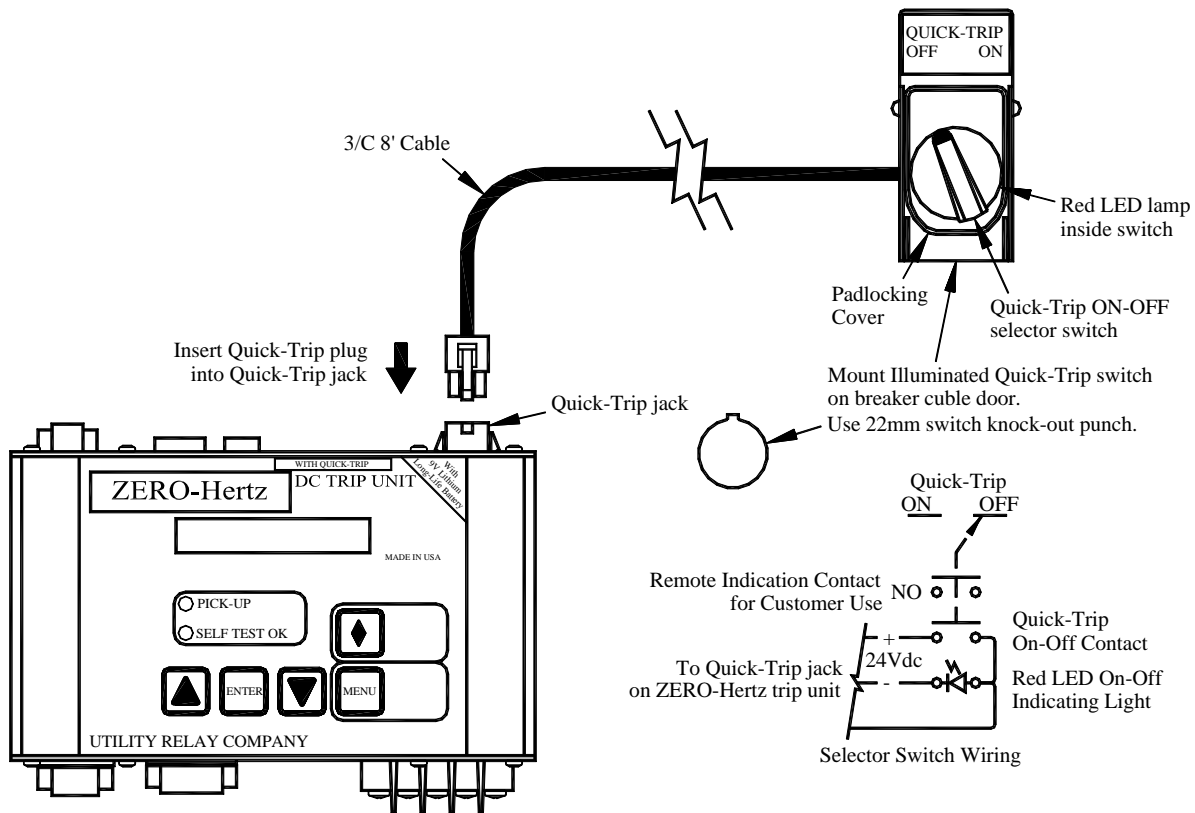

The Quick-Trip system is a manually controlled Zone Selective Interlock (ZSI) system. It can reduce trip times when turned on and allows selective coordination between circuit breakers when turned off.

If maintenance personnel must work on energized equipment, they will first turn the Quick-Trip system on at the breaker feeding the equipment (the upstream breaker). If a fault now occurs, the upstream breaker will trip quickly based on the Quick-Trip settings **reducing the Arc Flash Hazard to personnel.**

When the work is done, the Quick-Trip system is turned off and the original selective coordination is back in effect.

For the ZERO-Hertz trip unit, the Quick-Trip system consists of the following components:

1. ZERO-Hertz trip unit with the Quick-Trip option.
2. Illuminated selector switch, with padlock cover, mounted on the breaker cubicle door that is used to turn Quick-Trip on and off.

When Quick-Trip is on, the following settings are enabled:

- Instantaneous Quick-Trip (IQT)
- GF Quick-Trip (GFQT)

All other settings remain in effect.

The illuminated selector switch provides positive indication that the Quick-Trip settings are active. If the selector switch lamp is on, then Quick-Trip is active.

***** IMPORTANT *****

A qualified engineer must determine the Quick-Trip settings, calculate the incident energy levels and determine the Hazard Risk Categories (HRC).

4.0 Security Key

The **ZERO-Hertz** trip unit contains a security feature that only allows someone familiar with the operation of the trip unit to commission the trip unit or make changes to the settings.

The "key" is simply a short jumper wire that is connected between the two terminals marked "KEY" on the top of the trip unit.

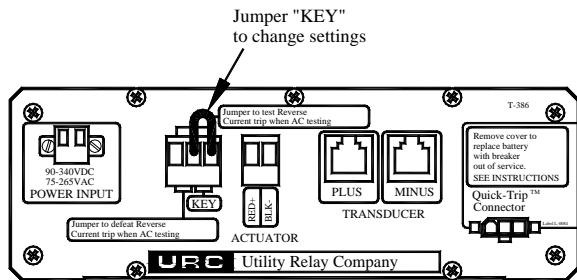

To install the security key:

Jumper the two terminals labeled "KEY" on the top of the trip unit.

To remove the security key:

Remove the jumper wire.

The key allows the user to commission the trip unit or to change the settings on a trip unit by performing the following steps:

- 1) Install the security key. This will put the trip unit in the programming mode.
- 2) Input settings to commission a new trip unit or change the settings on a previously commissioned trip unit (see Section 5.0).
- 3) Remove the security key. This will save the new settings in the trip unit's non-volatile EEPROM memory.

**** IMPORTANT ****
 The security key must be removed prior to placing the breaker into service for the trip unit to function properly. The trip unit's display will prompt the user to remove the key.

5.0 Commissioning

Prior to placing the **ZERO-Hertz** trip unit into service, it must first be commissioned. This requires the user to enter all of the pick-up and delay settings into the unit before it will function. The commissioning process normally takes less than a few minutes to complete.

The **ZERO-Hertz** is commissioned as follows:

- 1) Install the security key (see Section 4.0)
- 2) Power-up the trip unit by pressing the **REVIEW** button (see Section 5.1). The trip unit will alternately display the following:

ENTER DATA

SERIAL # XXXXXXXX

- 3) Press the **SAVE** button to begin the commissioning process.
- 4) Enter the appropriate pick-up and delay settings (see Sections 5.3 thru 5.26)

This same procedure is used to reprogram a trip unit that has already been commissioned.

5.1 Powering-Up The Trip Unit

The **ZERO-Hertz** trip unit can be powered-up in either of the following two ways.

1.) Internal Battery

Press the **REVIEW** button to power-up the trip unit using the internal battery.

While powered from the battery, the trip unit is designed to shut off automatically if none of the 4 push buttons on the face of the unit are pressed for 30 seconds. Therefore, it is best to have all the desired setting readily available before commissioning the unit when using the battery.

If the trip unit shuts down before the commissioning process is completed, the process must be started again from the beginning.

2.) External Power

Apply 90-340 Vdc or 75-265 volts Vac to the external power terminals located on the top of the trip unit. 120 Vac is usually the most convenient.

By applying external power, the unit will stay energized as long as necessary to complete the commissioning process.

When the trip unit is energized, the following will alternate on the display if the trip unit has not already been commissioned:

ENTER DATA

SERIAL # XXXXXXXX

Press the **SAVE** push button to continue.

5.2 Security Key During Commissioning

The following will be displayed if the security key is not already installed:

SECURITY KEY OFF

Install the security key to continue the commissioning process. See Section 4.0.

5.3 Transducer / Shunt Input Select

If the trip unit *does not* have the shunt input option, with the shunt connections on the bottom of the trip unit, proceed to Section 5.4

If the trip unit has the shunt input option, the following will be displayed:

INPUT XDUCER

Where "XDUCER" represents the method of sensing current.

If the trip unit is going to be used with a transducer(s), press the **SAVE** button.

If the trip unit is going to be connected directly to a DC metering shunt as a method of sensing current, press the **UP** push button.

The following will be displayed:

INPUT SHUNT

Press the **SAVE** button to continue.

**** NOTE ****

The **DOWN** button can be pressed to reselect the XDUCER inputs before pressing the **SAVE** button.

5.4 Transducer / Shunt Rating

If the XDUCER input was selected, the following will be displayed:

XDUCER XXXXA

Where "XXXX" represents the transducer rating in amps.

If the SHUNT input was selected, the following will be displayed:

SHUNT XXXXA

Where "XXXX" represents the shunt rating in amps.

The XDUCER / SHUNT rating ranges from 100 amps to 5,000 amps in 25 amp steps, and from 5,000 amps to 30,000 amps in 250 amp steps.

The XDUCER/SHUNT rating entered into the trip unit **must** correspond to the actual rating of the shunt or the rating the transducer will be calibrated to. A security feature is provided so the XDUCER/SHUNT rating will not be accidentally changed later.

The security feature must be used to enter the initial XDUCER/SHUNT rating or to change the rating.

*****To Activate the Security Feature*****

- **In the commissioning mode**
- **When the shunt or transducer rating is displayed**
- **Push and hold the REVIEW push button then push the SAVE push button. Release both push buttons**
- **This allows the transducer/shunt rating to be changed**

With the security feature activated, press and hold the **UP** or **DOWN** button as required until the correct XDUCER / SHUNT rating is displayed.

Press the **SAVE** button to continue.

5.5 Long Time (LT) Pick-Up Setting

The following will be displayed:

LT PICK-UP XXXXA

Where "XXXX" represents the LT Pick-Up setting in amps. The LT Pick-Up setting ranges from 40% to 100% of the transducer rating. This setting is adjustable in 5 amp steps (50 amp steps for transducers greater than 5000 amp).

Press and hold the **UP** or **DOWN** button as required until the correct LT Pick-Up setting is displayed.

Press the **SAVE** button to continue.

5.6 Long Time (LT) Delay Setting

The following will be displayed:

LT DELAY XX.XSEC

Where "XX.X" represents the LT Delay band. The LT Delay band is labeled by the number of seconds to trip at 6 times the LT Pick-Up setting.

The LT Delay setting ranges from 2.5 to 30 seconds in steps of 0.5 seconds. **This provides 56 LT Delay bands.**

Press and hold the **UP** or **DOWN** button as required until the correct LT Delay setting is displayed.

Press the **SAVE** push button to continue.

5.7 Long Time (LT) Thermal Memory

The following will be displayed:

LT THERMAL ON

If the Thermal Memory **is desired**, press the **SAVE** push button and go to Step 5.8.

If the Thermal Memory **is not desired**, press the **DOWN** button and the following will be displayed:

LT THERMAL OFF

Thermal Memory **ON** mimics the cooling of cables after an overload. If the current goes above the LT PICK-UP with the Thermal Memory **ON**, the LT register starts at a value representing any retained heat in the cables from recent overloads and result in a faster trip.

With Thermal Memory **OFF**, an overload that drops below the LT PICK-UP will reset the LT register. If the current goes above the LT PICK-UP again, the LT register starts from zero.

Press the **SAVE** push button to continue.

5.8 Short Time (ST) Pick-Up Setting

The following will be displayed:

ST PICK-UP OFF

If the ST function is **not desired**, press the **SAVE** push button and go to Step 5.11.

If the ST function **is desired**, press the **UP** button and the following will be displayed:

ST PICK-UP XXXXA

Where "XXXX" represents the ST Pick-Up in amps.

The ST Pick-Up setting range is 150% to 1100% of the LT Pick-Up setting in 100 amp steps (1000 amp steps for transducer or shunt ratings greater than 5000 amps). Press and hold the **UP** or **DOWN** button as required until the correct ST Pick-Up setting is displayed.

Press the **SAVE** push button to continue.

5.9 Short Time (ST) Delay Setting

If the ST function is **ON**, then the following will be displayed:

ST DELAY .XXSEC

Where ".XX" represents the ST Delay.

The ST Delay settings are .07, .10, .15, .20 and .35 seconds.

Press and hold the **UP** or **DOWN** button as required until the correct ST Delay setting is displayed.

Press the **SAVE** push button to continue.

5.10 Short Time (ST) I²T

If the ST function is **ON**, then the following will be displayed:

ST I SQ T OFF

If the I²T ramp is **not desired**, press the **SAVE** button to move to the next setting.

If the ST I²T ramp **is desired**, press the **UP** button. The following will be displayed:

ST I SQ T ON

Pushing the **DOWN** button will turn the ST I²T ramp off again.

Press the **SAVE** button to continue.

5.11 Instantaneous (I) Pick-Up Setting

The following will be displayed:

I PICK-UP XXXXXA

Where "XXXXX" represents the I Pick-Up in amps.

The I Pick-Up setting range is 150% to 1100% of the LT Pick-Up setting in steps of 100 amps (1000 amp steps for transducers greater than 5000 amps).

Press and hold the **UP** or **DOWN** button as required until the correct I Pick-Up setting is displayed.

If the I function is **not desired** and the ST function is **not off**, press the **DOWN** button until the following is displayed:

I PICK-UP OFF

**** CAUTION ****
The trip unit does not allow having both the ST and the I functions off at the same time.

Press the **SAVE** push button to continue.

5.12 Ground Fault (GF) Pick-Up Setting

If the XDUCER Inputs are selected, the following will be displayed:

GF PICK-UP OFF

If the GF function is **not desired**, press the **SAVE** push button and go to Step 5.16.

If the GF function **is desired**, press the **UP** button and the following will be displayed:

GF PICK-UP XXXXA

Where "XXXX" represents the GF Pick-Up setting in amps.

The GF Pick-Up setting range is 40% to 200% of the transducer rating in steps of 10 amps (100 amp steps for transducers greater than 5000 amps).

Press and hold **UP** or **DOWN** button as required until the correct GF Pick-Up setting is displayed.

Press the **SAVE** push button to continue.

5.13 Ground Fault (GF) % Restraint

The GF Trip Function includes a percentage restraint feature to reduce the possibility of a nuisance GF trip when the breaker experiences high current such as during motor starting.

For currents greater than two times the transducer rating, the GF Pick-Up value is temporarily increased by 20% of the magnitude of the current above two times the transducer rating.

5.14 Ground Fault (GF) Delay Setting

If the GF function is **ON**, then the following will be displayed:

GF DELAY .XXSEC

Where ".XX" represents the GF Delay.

The GF Delay settings are .10, .20, .30, .40 and .50 seconds.

Press and hold the **UP** or **DOWN** button as required until the correct GF Delay setting is displayed.

Press the **SAVE** button to continue.

5.15 Ground Fault (GF) I²T

If the GF function is **ON**, then the following will be displayed:

GF I SQ T OFF

If the I²T ramp is **not desired**, press the **SAVE** button to move to the next step.

If the GF I²T ramp is **desired**, press the **UP** button. The following will be displayed:

GF I SQ T ON

Pushing the **DOWN** button will turn the GF I²T ramp off again.

Press the **SAVE** button to continue.

5.16 Reverse Current (RC) Pick-Up Setting

The following will be displayed:

RC PICK-UP OFF

If the RC function is **not desired**, press the **SAVE** button and go to Step 5.19.

If the RC function is **desired**, press the **UP** button and the following will be displayed:

RC PICK-UP XXXXA

Where "XXXX" represents the RC Pick-Up setting in amps.

The RC Pick-Up setting range is 20% to 600% of the transducer/shunt rating in steps of 5 amps (50 amp steps for transducer/shunt ratings greater than 5000 amps).

Press and hold the **UP** or **DOWN** button as required until the correct RC Pick-Up setting is displayed.

Press the **SAVE** button to continue.

5.17 Reverse Current (RC) Delay Setting

If the RC function is **ON**, then the following will be displayed:

RC DELAY .XXSEC

Where ".XX" represents the RC Delay.

The RC Delay settings are .10, .20, .30, .40 and .50 seconds.

Press and hold the **UP** or **DOWN** button as required until the correct RC Delay setting is displayed.

Press the **SAVE** button to continue.

5.18 Reverse Current (RC) I²T

If the RC function is **ON**, then the following will be displayed:

RC I SQ T OFF

If the RC I²T ramp is **not desired**, press the **SAVE** push button to move to the next step.

If the RC I²T ramp is **desired**, press the **UP** push button. The following will be displayed:

RC I SQ T ON

Pushing the **DOWN** button will turn the RC I²T ramp off again.

Press the **SAVE** button to continue.

5.19 Quick-Trip™ Instantaneous (IQT) Pick-Up Setting

The following will be displayed:

IQT PICK-UP XXXXXA

Where "XXXXX" represents the IQT Pick-Up setting in amps.

The IQT Pick-Up setting range is 150% to 1100% of the LT Pick-Up setting in steps of 100 amps (1000 amp steps for transducers/shunts greater than 5000 amps).

Press and hold the **UP** or **DOWN** button as required until the correct IQT Pick-Up setting is displayed.

There is no **OFF** setting for IQT.

Press the **SAVE** push button to continue.

5.20 Quick-Trip™ Ground Fault (GFQT) Pick-Up Setting

GFQT is only available for XDUCER Input.

If the normal GF function is set to **OFF**, then an **OFF** setting is also available for GFQT. Otherwise GFQT will not have an **OFF** setting.

GFQT PICK-UP OFF

If the QTGF function is **not desired** press the **SAVE** push button and go to Step 5.21.

If the QTGF function is **desired**, press the **UP** button and the following will be displayed:

GFQT PICK-UP XXXXA

Where "XXXX" represents the QTGF Pick-Up setting in amps.

The QTGF Pick-Up setting range is 40% to 200% of the transducer rating in steps of 10 amps (100 amp steps for transducers greater than 5000 amps).

Press and hold **UP** or **DOWN** button as required until the correct QTGF Pick-Up setting is displayed.

Press the **SAVE** push button to continue.

5.21 COM Address

If the trip unit is **NOT** equipped with the communications option, proceed to Section 5.24.

If the trip unit is equipped with the communications option, then the following will be displayed:

COM ADDR XX

Where "XX" represents the trip unit communications address.

The address settings range from 1 to 127 in increments of 1. This unique address will identify individual trip units connected on the same twisted pair wire.

**** NOTE ****
Each twisted pair wire can support up to 32 trip units. Multiple twisted pairs can support hundreds of trip units.

Press and hold the **UP** or **DOWN** button as required until the correct COM Address is displayed.

Press the **SAVE** button to continue.

5.22 Reply Delay

This setting applies only to ZERO-Hertz trip units with the communication option and will not be displayed on non-communicating trip units.

The reply delay set point is the minimum delay between the trip unit's receipt of a MODBUS packet and its reply.

The reply delay can be either 5 or 10 milliseconds. The factory default is 5 milliseconds.

REPLY DELAY XXMS

Where "XXMS" represents either 5 or 10 milliseconds. Press the "UP" or "DOWN" push button as required until the desired delay setting is displayed.

Press the **SAVE** button to continue.

5.23 Alarm on COM

If the trip unit is equipped with the communications option, then the following will be displayed:

ALARM COM OFF

The factory default setting is **OFF**. Changing this setting to **ON** will put the alarm relay under the direct control of the communications port. The state of the relay is controlled directly from commands sent from a remote PC connected to the trip unit through this port.

With this setting **ON**, all other alarm relay settings are defeated except for loss of power. Proceed to Section 5.27 (Exit Procedure).

With this setting **OFF** all remaining alarm relay settings are enable. Proceed to Section 5.24.

Press the **UP** button for **ON** or the **DOWN** button for **OFF**.

Press the **SAVE** button to continue.

5.24 Alarm on Overload

The following will be displayed:

ALARM OL OFF

If the Alarm on Overload feature is not **desired**, press the **SAVE** button and go to Step 5.25.

If the Alarm on Overload feature **is desired**, press the **UP** button and the following will be displayed:

ALARM OL ON

Press the **SAVE** button to continue.

****** NOTE ******

Alarm on Overload, Alarm on Trip, and Alarm on ERROR, can be set to **ON** either individually or in any combination.

5.25 Alarm on Trip

The following will be displayed:

ALARM TRIP OFF

If the Alarm on Trip feature is not **desired**, press the **SAVE** button and go to Step 5.26.

If the Alarm on Trip feature **is desired**, press the **UP** button and the following will be displayed:

ALARM TRIP ON

Press the **SAVE** button to continue.

Pushing the **REVIEW** push button will reset the Alarm on Trip.

5.26 Alarm on ERROR

The following will be displayed:

ALARM ERROR OFF

If the Alarm on ERROR feature is not **desired**, press the **SAVE** button and go to Step 5.27.

If the Alarm on ERROR feature **is desired**, press the **UP** button and the following will be displayed:

ALARM ERROR ON

If set to **ON** the Alarm on ERROR feature will operate the alarm if the **SELF TEST OK** LED on the front of the trip unit turns **OFF** for any reason while the trip unit is in operation. See Sections 2.8 and 2.9.

Press the **SAVE** button to continue.

5.27 Exit Procedure

The following will be displayed:

SAVE IF DONE

REVIEW TO REVIEW

If it is desired to review the settings, push the **REVIEW** button. Make any changes necessary using the **UP** or **DOWN** buttons. As before, use the **SAVE** button to move to each new setting.

If the settings are as desired, push the **SAVE** button and the settings will be saved in the non-volatile EEPROM memory.

The following will be displayed:

REMOVE KEY TO

COMMISSION UNIT

Remove the "key". See section 4.0.

If the commissioning process was performed using the internal battery, the unit will turn itself off.

If the commissioning process was performed while supplying external power to the trip unit, the following will be displayed:

LOW CURRENT

The commissioning process is complete.

6.0 Changing Settings

**** IMPORTANT ****

While it is possible to make changes to the settings with the breaker in service, it is strongly recommended that THE BREAKER SHOULD BE REMOVED FROM SERVICE while making these changes since the trip unit will not provide protection during portions of this process.

After the trip unit is commissioned, settings can easily be changed in the following manner.

Close the security key. See Section 4.0.

Power up the trip unit by pressing **REVIEW** or by applying external power as described in Section 5.0, Commissioning.

Press the **REVIEW** button. The following will be displayed:

ENTER DATA

SERIAL # XXXXXXXX

Press the **SAVE** button.

Make any changes necessary using the **UP** or **DOWN** buttons. Use the **SAVE** button to move to each new setting.

After going through all the settings, the following will be displayed.

SAVE IF DONE

REVIEW TO REVIEW

If it is desired to review the setting, push the **REVIEW** push button. Make any changes necessary using the **UP** or **DOWN** buttons. As before, use the **SAVE** button to move to each new setting.

If the settings are as desired, push the **SAVE** button. The following will be displayed:

REMOVE KEY TO

COMMISSION UNIT

Remove the security key. See Section 4.0. The settings will be saved in the non-volatile EEPROM memory.

The Settings have been changed.

Remember that if the trip unit loses power during this process, the old settings will be retained and the process must be repeated.

7.0 Target Recall of Last Trip Data

The **ZERO-Hertz** has an especially useful **Target Recall** system.

After a breaker trip, the trip unit will display the type of trip (i.e. LT, ST, I, GF, UV OL, REVRs, GFQT or IQT as applicable) and then the current at the time of trip followed by the trip log and the settings. This information is saved in the non-volatile EEPROM memory and is available immediately after a trip or anytime thereafter.

**** NOTE ****

Only the data from the last trip is saved. The second time the breaker trips, the new trip data is written over the first trip data.

Pressing the **REVIEW** button will display the following two alternating messages, alternating at a 1.0 second interval rate:

LAST TRIP XX

XXXXX AMP

Where “XX” is the type of tripping event (i.e. LT, ST, I, GF, UV FAULT, REVRs, GFQT or IQT as applicable) and “XXXXX” is the magnitude of the current at the time of trip. If the breaker has two poles and two transducers are connected to the trip unit, then the current value displayed will be the greater of the two poles.

Pressing the **REVIEW** button again will display the following two alternating messages, alternating at a 1.0 second interval rate:

HOLD < REVIEW > TO

VIEW TRIP COUNTS

If the **REVIEW** key is pushed again and held down for more than 2 seconds, the trip counter memory is accessed and the following will be displayed

INST TRIPS: XX

The “XX” represents the number of times the trip unit has tripped on the Instantaneous function.

Each successive press of the **REVIEW** button will display the number of trips for the additional functions as follows:

LT TRIPS: XX

ST TRIPS: XX

GF TRIPS: XX

FORCE TRIPS: XX

REVRs TRIPS: XX

UV OL TRIPS: XX

GFQT TRIPS: XX

IQT TRIPS: XX

Continuing to press the **REVIEW** button will step through a review of the settings that are currently programmed in to the trip unit.

**** NOTE ****

Pushing the **SAVE, UP** or **DOWN** buttons during "target recall" has no effect because the "key" is not on. No settings can be changed without using the “key”.

To erase the Last Trip Data and the trip counter from memory, refer to Section 9.9. After the Last Trip Data has been erased, pressing the **REVIEW** button will display the following:

NO LAST TRIP

8.0 Normal Operation

Breaker Current Less than 20% of Transducer/Shunt Rating:

With the trip unit in service, and the breaker current less than 20% of the transducer/shunt rating, the display will show the following:

LOW CURRENT

Breaker Current Greater than 20% of Transducer/Shunt Rating:

If the breaker current is greater than 20% of the transducer/shunt rating but less than the LT pick-up value or GF pick-up value (if applicable), the following will be shown on the display.

CURRENT XXXXX A

When the trip unit detects an overload situation, the "PICK-UP" light on the front of the trip unit will illuminate, and the following will alternately be shown on the display at .5 second intervals:

CURRENT XXXXX A

OVERLOAD

9.0 Testing & Calibration – Transducers Input

**** WARNING ****

Always REMOVE FUSES from the fuse block supplying power to the trip unit when testing the breaker. This includes high current injection testing, meggering or any other test, which requires energizing the breaker stabs or control wiring supplying power to the trip unit.

Failure to REMOVE FUSES while testing can result in permanent damage to the trip unit.

Be sure to REPLACE FUSES before placing the breaker in service.

A "primary injection" test is recommended as the initial test of the **ZERO-Hertz** retrofit. If a DC high current test set is available, it should be used for calibration and all functional tests of the trip unit.

If an AC high current test set is the only type available, it should be used for calibration and to test the trip unit's pick-up, timing accuracy and repeatability for the Long-Time, Short-Time, Instantaneous, Reverse Current and Ground Fault functions (On some breakers only a DC high current test set can be used. This will be indicated in the kit installation manual.).

When testing the trip unit, it is important to remember that the trip unit requires control power to operate during calibration and testing. To power the trip unit, simply remove the wires that connect the trip unit power inputs to the breaker stabs or control wiring and apply a suitable power source to those two terminals on the trip unit. Be sure to observe the control power voltage range, which is clearly marked above the terminals on the top of the trip unit.

**** WARNING ****

Only apply control power to the terminals clearly marked as the **Power Input** on the top of the trip unit. Also observe the voltage restrictions marked on the top of the trip unit.

DO NOT apply power to any other terminals on the trip unit. Applying power to any terminals other than the Power Input terminals will cause SEVERE DAMAGE and voids the warranty of the trip unit.

9.1 Step 1: Commission the Trip Unit

Before proceeding with the normal primary injection tests, the trip unit must be commissioned to make it functional. See Section 5.0 for the commissioning procedure. It is best to use the final pick-up and time delay settings if they are known. If not, use typical settings for the primary injection test.

It is important to remember that control power must be applied to the trip unit during primary injection testing. 120VAC can be used.

If the transducer is not properly connected, the trip unit's LCD will display:

CHECK XDUCERS

until the connection is correct. The **SELF TEST OK** LED will be off until the connections are correct.

9.2 Step 2: Verify Transducer Installation

INSTALLATION ON A ONE POLE BREAKER

It is important to verify that the transducer is properly oriented on the breaker bus with regard to the direction of the flow of current on the “+” pole of the breaker.

To ensure proper transducer orientation, verify that the label on the side of the transducer (shown below) is oriented such that the arrow points in the same direction as the flow of current (i.e. from the source to the load) on the “+” pole of the breaker.

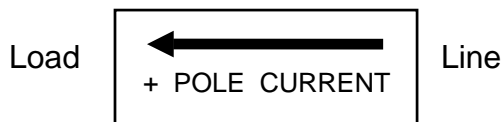

Improper orientation of the transducer on the “+” pole will result in a reverse current nuisance trip if the Reverse Current (RC) function is on.

If the transducer is not oriented properly on the breaker bus, unscrew the transducer from the bus, rotate the transducer 180 degrees and refasten to the bus using the existing screw. It will be necessary to re-calibrate the transducer if it must be repositioned on the bus (see section 9.4).

Also verify that the transducer is connected to the “+ TRANSDUCER” input on the top of the trip unit.

**** NOTE ****
 The Ground Fault (GF) function can only be implemented on a two pole breaker with both the “+” and “-” transducers connected. If the GF function was turned ON during the commissioning process, the trip unit will automatically defeat this function if only the “+” transducer is being used.
 The GF feature is not available for shunt input.

INSTALLATION ON A TWO POLE BREAKER

The **ZERO-Hertz** trip unit can be installed on a two pole breaker with only one transducer by installing the transducer on the “+” pole of the breaker. However, an addition transducer must also be used on the “-” pole of the breaker in order to implement the Ground Fault (GF) function.

It is important to verify that the transducers are properly oriented on the breaker bus with regard to the direction of the flow of current. To ensure proper transducer orientation, check the following:

- 1.) For the transducer installed on the “+” pole of the breaker; verify that the label on the side of the transducer (shown below) is oriented such that the arrow at the side of the label points in the same direction as the flow of current on the “+” pole (i.e. from the source to the load).
- 2.) For the transducer installed on the “-” pole of the breaker, the orientation of the transducer does not matter since this transducer is not used to detect current direction. Only the absolute value of the current is determined and used to calculate the Ground Fault current.

Also verify that the transducer installed on the “+” pole is connected to the “+ SENSOR” input on the top of the trip unit.

9.3 Step 3: Defeat RC (if so equipped)

If the trip unit has the Reverse Current function turned on, it will be necessary to defeat it when testing with an AC high current test set.

To defeat Reverse Current, jumper the “AC Test” terminals located on the top of the trip unit.

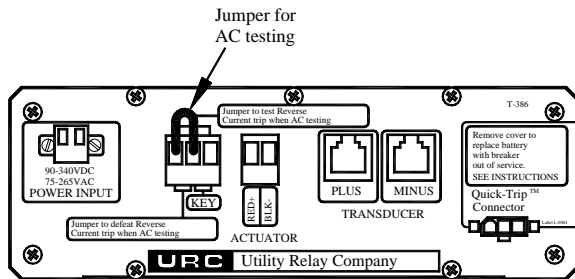

9.4 Step 4: Calibrate the Transducers

After the installation of the **ZERO-Hertz** retrofit kit, it is necessary to calibrate the transducer(s) to match the transducer rating programmed into the trip unit during the commissioning process.

****** IMPORTANT ******
 The transducer must never be calibrated so that its rating exceeds the continuous current rating of the breaker.

The transducers are calibrated using the 16-turn adjustment screw located on the face of each transducer next to the wiring connector.

To calibrate the transducer on the “+” pole of the breaker perform the following:

- 1.) Unplug the “-” pole transducer from the trip unit if the breaker is so equipped. This will automatically defeat the Ground Fault function.
- 2.) Connect an AC or DC high current test set to the “+” pole stabs of the breaker. The kit installation manual will indicate if an AC high current test set can be used.

(Remember to jumper the “AC Test” terminals on the top of the trip unit when using an AC test set and reverse current is on).

- 3.) Apply control power to the trip unit. 120Vac can be used.
- 4.) Inject a test current through the “+” pole of the breaker which is approximately equal to the transducer rating programmed into the trip unit.
- 5.) With the current flowing, adjust the transducer rating adjustment screw, located on the “+” pole transducer next to the wiring connector, until the trip unit’s LCD display’s the same current value which is being injected into the breaker.
- 6.) Discontinue injecting current, the calibration process for the “+” transducer is now complete.

For a two pole breaker with two transducers, the “-” pole transducer must be calibrated as follows:

- 1.) Unplug the “+” pole transducer from the trip unit. This will automatically defeat the Ground Fault function. NOTE: The “SELF TEST OK” LED on the trip unit will go out.
- 2.) Connect an AC or DC high current test set to the “-” pole stabs of the breaker. . The kit installation manual will indicate if an AC high current test set can be used.
- 3.) Apply control power to the trip unit. 120Vac can be used.
- 4.) Inject a test current through the “-” pole of the breaker which is approximately equal to the transducer rating programmed into the trip unit.
- 5.) With the current flowing, adjust the transducer rating adjustment screw, located on the “-” pole transducer next to the wiring connector, until the trip unit’s LCD display’s the same current value which is being injected into the breaker.
- 6.) Discontinue injecting current, the calibration process is now complete.

When the calibration process is completed, make sure that all of the transducer cables are properly reconnected.

9.5 Step 5: Defeat GF (if so equipped)

If the trip unit is equipped with the Ground Fault function, it will be necessary to defeat ground fault trip to test the remainder of the functions.

Temporarily disconnect the cable going to the transducer on the pole *NOT* being tested. This will turn off the GF function.

To test the Ground Fault function, inject current from the line to the load stabs on one pole of the breaker with both transducers connected.

9.6 Step 6: Verify Pick-Up and Calibration

To test the LT Pick-Up, increase the current until the “Pick-Up” LED illuminates. Observe that the injected current corresponds to the programmed LT Pick-Up setting.

9.7 Step 7: Primary Injection Tests

Proceed with the normal primary injection test to verify the pick-up and time delay of the various trip functions. The pick-up and time values should be within the tolerance band of the **ZERO-Hertz** time-current curves.

When testing the time delay of a trip function, the test current must be at least 10% greater than the pick-up setting for that function.

9.8 Step 8: Reverse Current (RC) Testing

When using an AC high current test set, installing a jumper wire as shown below can test the Reverse Current (RC) function. This forces the trip unit to consider the “+” pole current as reverse current.

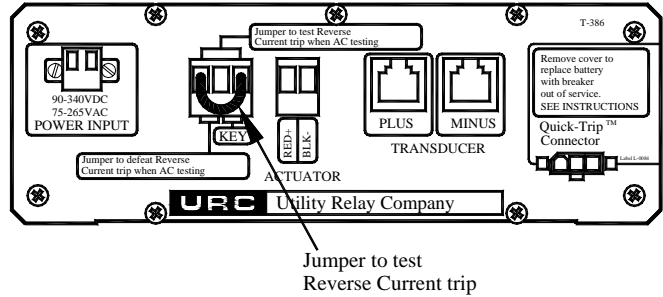

Proceed with the normal primary injection test to verify the pick-up and time delay of the RC function. The pick-up and time values should be within the tolerance band of the **ZERO-Hertz** time-current curves.

The direction of current flow is only determined by the “+” pole. Do NOT try to test the “-” pole for the RC trip function.

9.9 Step 9: Erase Last Trip Data

After completing the primary injection test, it is important to erase the last trip data from the memory of the trip unit.

**** IMPORTANT ****
Erase the last trip data from the memory of the trip unit after completing the primary injection tests.

To erase the memory in the trip unit after completing the primary injection tests, use one the following methods:

Method 1:

- 1) The trip unit should not be powered-up.
- 2) Install the security key. See section 4.0.
- 3) Push and hold both the **UP** and **DOWN** push buttons.
- 4) While continuing to hold the **UP** and **DOWN** buttons, push the **REVIEW** button. Release all buttons. The following will be displayed:

UN-COMMISSION?

- 5) If the settings made during the commissioning procedure are to be erased, press the **UP** button. If the settings are **not** to be erased, push the **DOWN** button.
- 6) The following will be displayed:

ERASE LAST TRIP?

- 7) If the last trip data is to be erased, press the **UP** button. If the data is **not** to be erased, push the **DOWN** button.
- 8) The trip unit will turn OFF. Remove the security key. All appropriate changes are completed.

Method 2:

- 1) With the unit powered-up, press the **REVIEW** button until the last trip data is displayed.
- 2) Push and hold in both the **UP** and **DOWN** buttons.
- 3) While continuing to hold the **UP** and **DOWN** buttons, push the **SAVE** button to clear the last trip data. The following will be displayed:

NO LAST TRIP

Last Trip Data has been erased.

**** IMPORTANT ****
If the last trip data is not erased after the primary injection test, the operating personnel may later assume that the breaker interrupted a fault at some time in the past when they check the last trip data.

10.0 Testing – Shunt Input

Primary injection testing is usually not practical when shunt input is used.

Accurate pick-up and timing tests of the shunt input can be made using Utility Relay Company's **ZERO-Hertz** Secondary Injection Test Set.

Alternatively, other test equipment that provides an adjustable milli-Volt signal can be used.

The recommended signal ranges are:

50 milli-Volt Shunt: 0 to 500 milli-Volt
100 milli-Volt Shunt: 0 to 1000 milli-Volt

11.0 Ratings

Ambient Temperature:

- Trip Unit: -4°F (-20°C) to 150°F (65°C)
- LCD Display:
 - Standard Temp, Supper Twist
 - 32°F (0°C) to 122°F (50°C)
- Humidity: 95% non-condensing

Conformal Coating:

- Polyurethane conformal coating
- HumiSeal type 1A33

Current Transducers:

- 1 milli-Amp secondary at rated current.
- Linear to 12 milli-Amp

Shunt Input:

- 50mV shunt input, linear to +/- 550mV
- 100mV shunt input, linear to +/- 1100mV
- 1000VDC maximum recommended operating system voltage
- 3750VDC isolation for 60 sec.

Enclosure:

- Extruded aluminum housing
- 6.76" X 3.84" X 2.28" nominal overall dimensions

12.0 Warranty

A conditional 2-year warranty is offered with each **ZERO-Hertz** trip unit.

Contact Utility Relay Company, LTD for full details.

13.0 Time-Current Curve

The Time-Current curves are shown on the last pages of this manual.

The curves are shown on log-log graph with seconds in the vertical direction and normalized current in the horizontal direction.

Overload and fault currents are shown as multiples of the LT pick-up setting. Ground and Reverse currents are shown as a percentage of the transducer rating.

The curves for the following time bands:

LT
ST I²T
GF I²T
RC I²T

are based on the following equation:

$$I^2T = \text{Constant}$$

Where: I is current in amps

T is time to trip in seconds (center of the band)

The tolerance for the bands is $\pm 10\%$ in the current direction. Based on the Time vs. Current trip equation ($I^2T = \text{Constant}$) for the LT trip function, the mathematical tolerance in the time direction for LT is +23.5% and -17.4%. The tolerances in the time direction for the other functions are graphically shown on the Time-Current curves.

13.1 LT Trip Time

For overload currents, the above equation can be restated as follows:

$$T = TBC_{LT} \text{ divided by } X^2$$

Where: **T** = time to trip in seconds (center of the band)

X = current in multiples of the LT pick-up setting

TBC_{LT} = the LT Time Band Constant = 36 X LT time band setting

**** NOTE ****

The LT Time Band Constant (TBC_{LT}) = 36 X The LT Time Band Setting in seconds.

EXAMPLE #1:

Transducer Rating	1600A
LT pick-up	1200A
LT time band	20S
Test Current	3600A

$$TBC_{LT} = 36 \times \text{LT Time Band Setting} = 36 \times 20 = 720$$

$$\text{and } X = 3600A / 1200A = 3$$

$$\text{Therefore: trip time} = T = TBC_{LT} / X^2 \text{ or } 720/3^2 = 720/9 = 80 \text{ seconds}$$

**** NOTE ****

To determine the LT trip time by calculation:

- 1) Calculate the LT Time Band Constant (TBC_{LT})
- 2) Calculate "X" where:

$$X = \frac{\text{(test current)}}{\text{(LT Pick-Up Setting)}}$$
- 3) Solve the equation:
 trip time(sec) = TBC_{LT} divided by X²

13.2 ST Trip Time

With I²T off or for currents greater than 10 X LT Pick-Up Setting, the ST trip time is a constant equal to the ST Time Band setting.

With I²T on and for currents less than 10 X LT Pick-Up Setting, the ST trip time is determined by the following equation:

$$T = TBC_{ST} \text{ divided by } X^2$$

Where: **T** = time to trip in seconds (center of the band)

X = current in multiples of the LT pick-up

TBC_{ST} = the ST Time Band Constant

**** NOTE ****

The ST Time Band Constant (TBC_{ST}) =

- 35 for the .35S Time Band
- 20 for the .20S Time Band
- 15 for the .15S Time Band
- 10 for the .10S Time Band
- 7 for the .07S Time Band

EXAMPLE #2:

Transducer Rating	1600A
LT pick-up	1200A
ST pick-up	6000A
ST time band	.20S I ² T ON
Test Current	7200A

$$TBC_{ST} = 20$$

$$X = 7200A/1200A = 6$$

$$\text{Therefore: trip time} = T = TBC_{ST} / X^2 \text{ or } 20/6^2 = 20/36 = .556 \text{ seconds}$$

**** NOTE ****

To determine the ST I²T trip time by calculation:

- 1) Determine the ST Time Band Constant (TBC_{ST})
- 2) Calculate "X" where

$$X = \frac{\text{(test current)}}{\text{(LT Pick-Up Setting)}}$$
- 3) Solve the equation:
 trip time(sec) = TBC_{ST} divided by X²

13.3 GF Trip Time

With I²T off or for currents greater than 2 times the transducer rating, the GF trip time is a constant equal to the GF Time Band setting.

With I²T on and for currents less than 2 times the transducer rating, the GF trip time is determined by the following equation:

$$T = \text{TBC}_{\text{GF}} \text{ divided by } X_{\text{GF}}^2$$

Where: **T** = time to trip in seconds (center of the band)

X_{GF} = current/ transducer rating

TBC_{GF} = the GF Time Band Constant

**** NOTE ****

The GF Time Band Constant (TBC_{GF}) =
 2.0 for the .50S Time Band
 1.6 for the .40S Time Band
 1.2 for the .30S Time Band
 0.8 for the .20S Time Band
 0.4 for the .10S Time Band

EXAMPLE #3:

Transducer Rating	1600A
LT pick-up	1200A
GF pick-up	800A
GF time band	.20S I ² T ON
Current	640A

$$\text{TBC}_{\text{GF}} = .80$$

$$X_{\text{GF}} = 800\text{A}/1600\text{A} = .50$$

Therefore: trip time = T = TBC_{GF} / X² or
 $.80/ (.50)^2 = .80/.25 = 3.20 \text{ sec}$

**** NOTE ****

To determine the GF I²T trip time by calculation:

- 1) Determine the GF Time Band Constant (TBC_{GF})
- 2) Calculate "X_{GF}" where:

$$X_{\text{GF}} = \frac{\text{(test current)}}{\text{(Transducer Rating)}}$$
- 3) Solve the equation:
 trip time(sec) = TBC_{GF} divided by X_{GF}²

ZERO-Hertz DC Trip Unit
Overload Time Current Curve

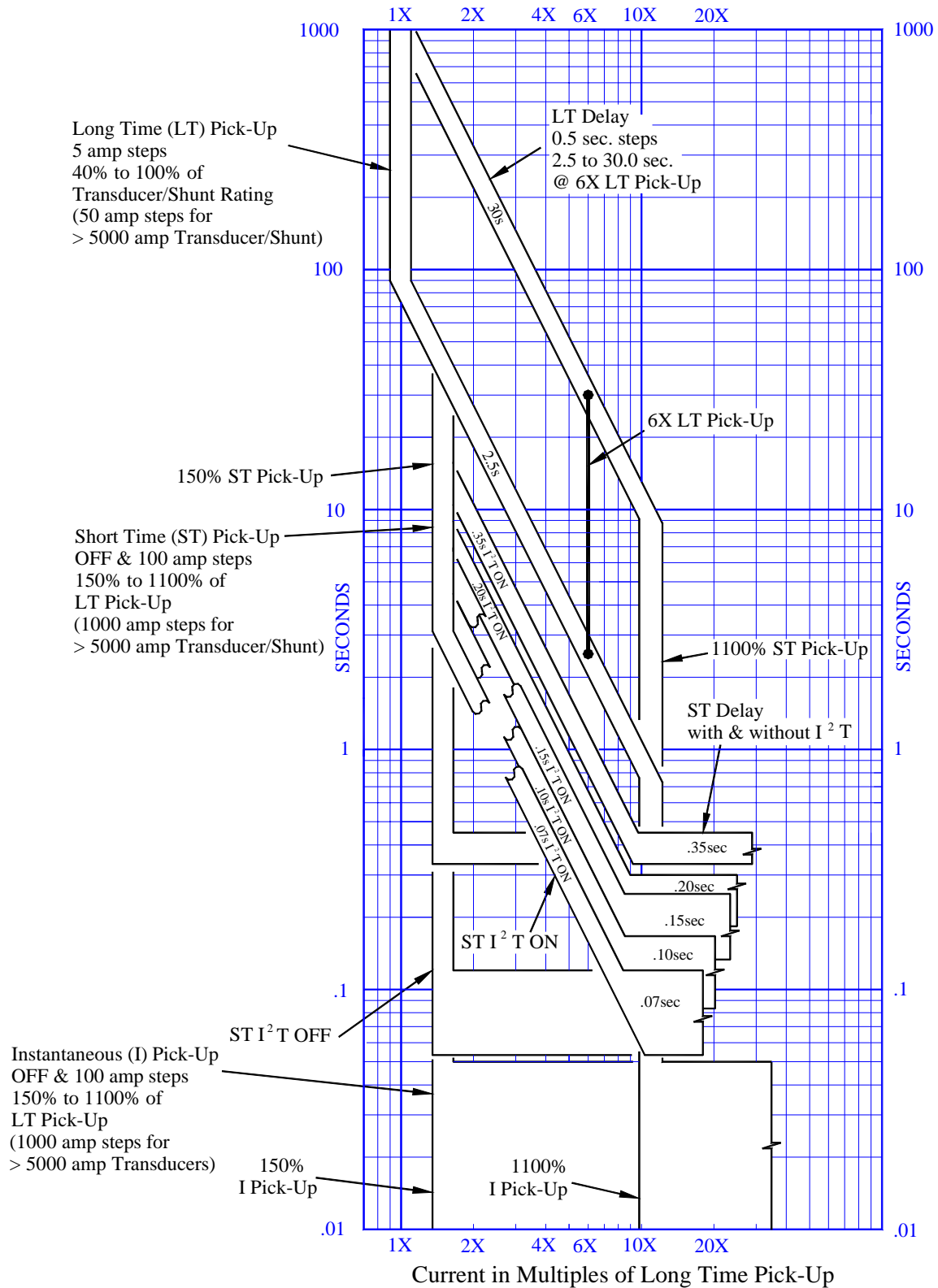

Figure 13.4 Overload TCC

THIS PAGE INTENTIONALLY LEFT BLANK

ZERO-Hertz DC Trip Unit

Reverse Current Time Current Curve

Ground Fault Time Current Curve

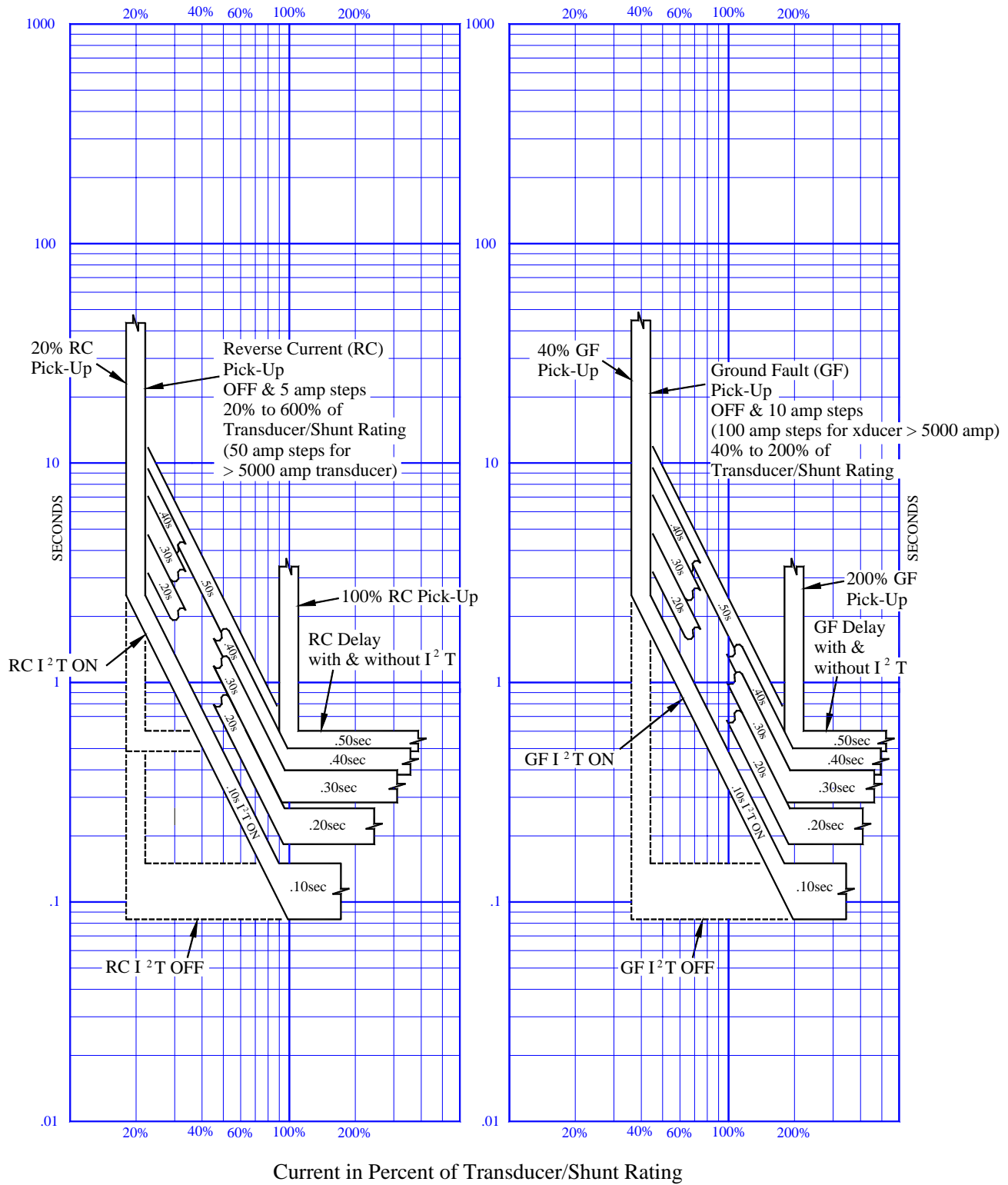

Figure 13.5 Reverse & GF TCC

THIS PAGE INTENTIONALLY LEFT BLANK

ZERO-Hertz DC Trip Unit

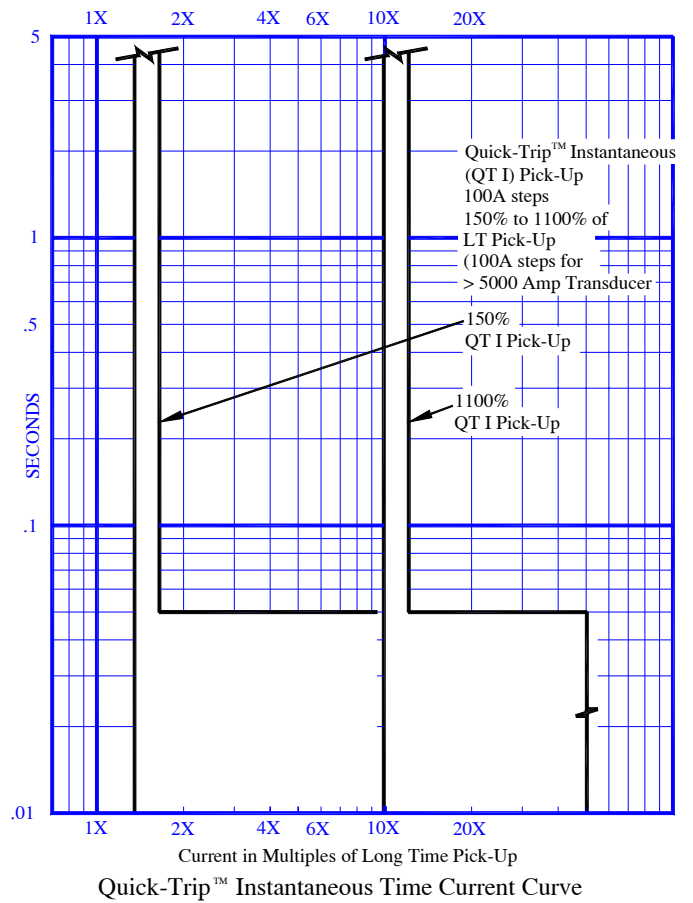
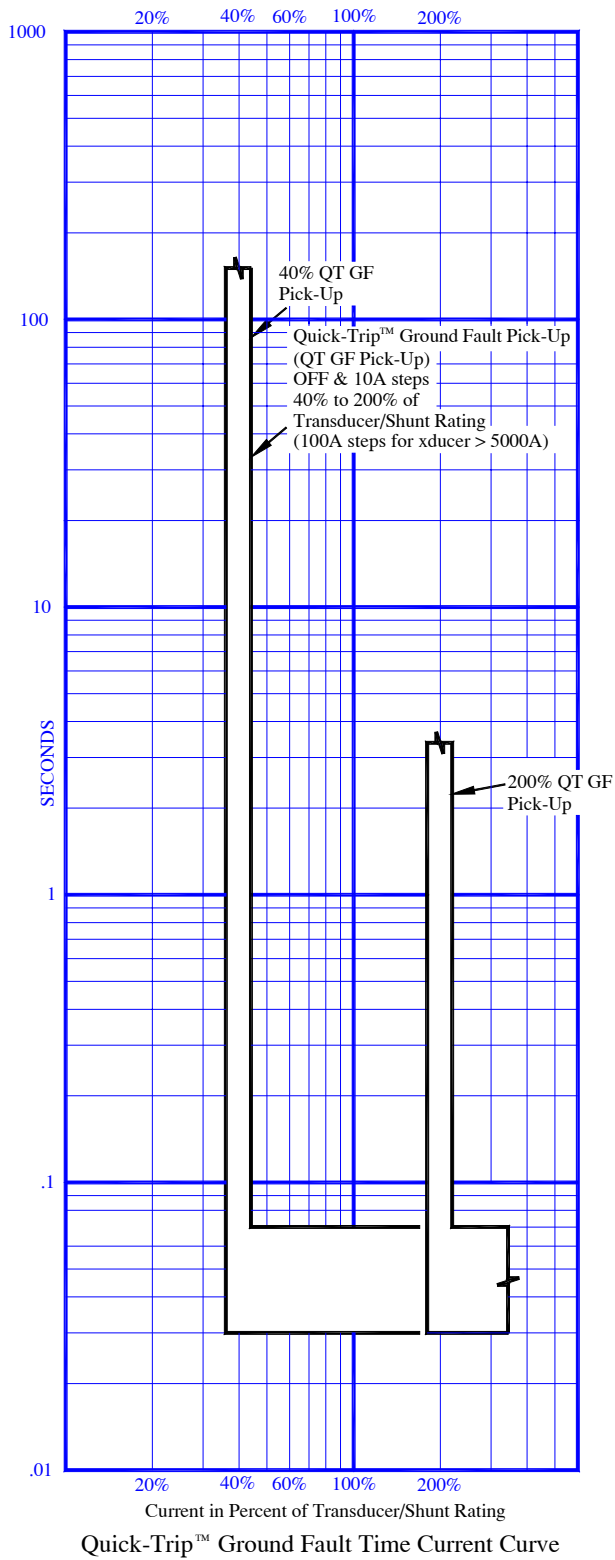

Figure 13.6 Quick-Trip™ Ground Fault & Instantaneous TCC

PAGE INTENTIONALLY LEFT BLANK

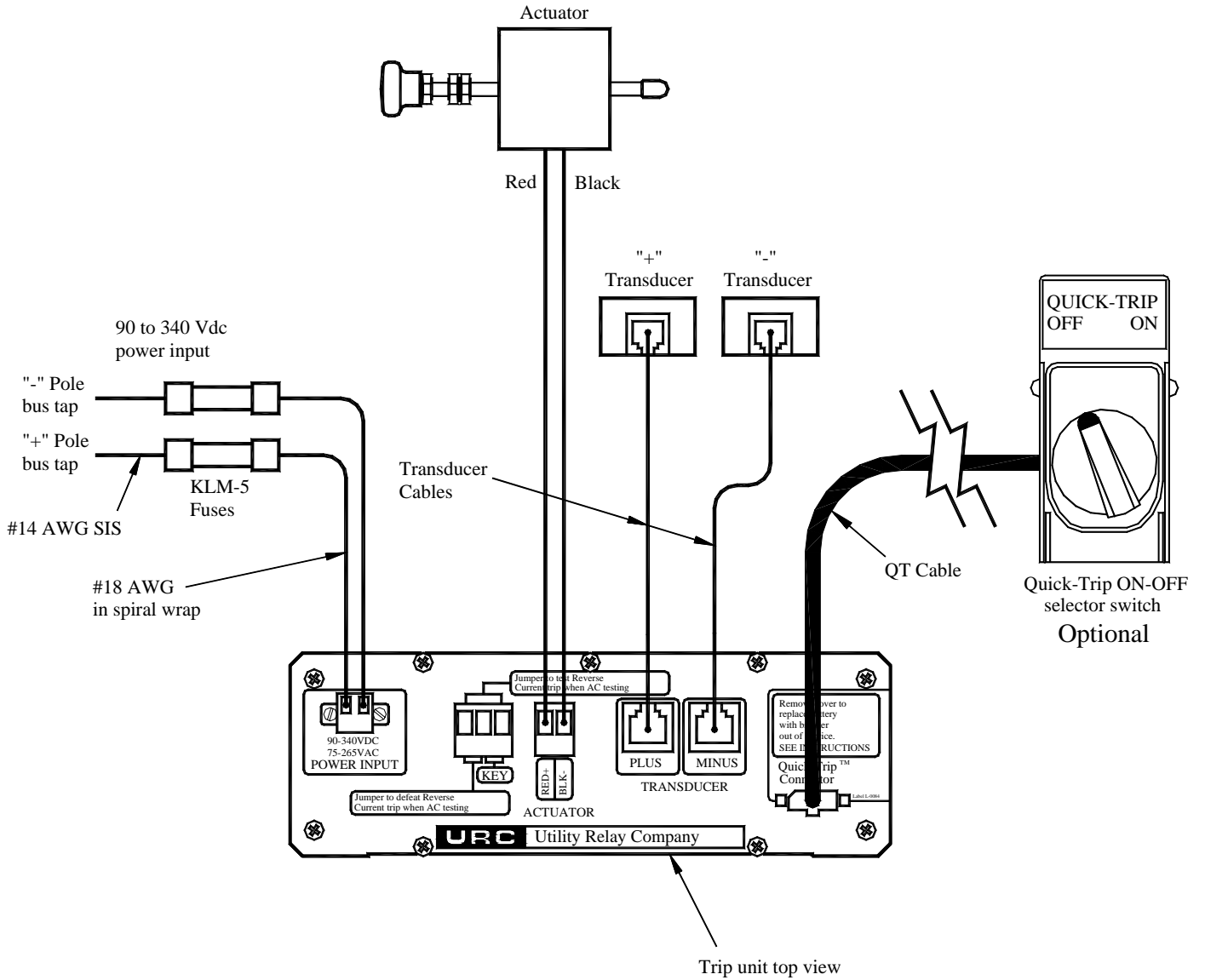

Figure 14.1 Typical Wiring Diagram-Using Actuator

THIS PAGE INTENTIONALLY LEFT BLANK

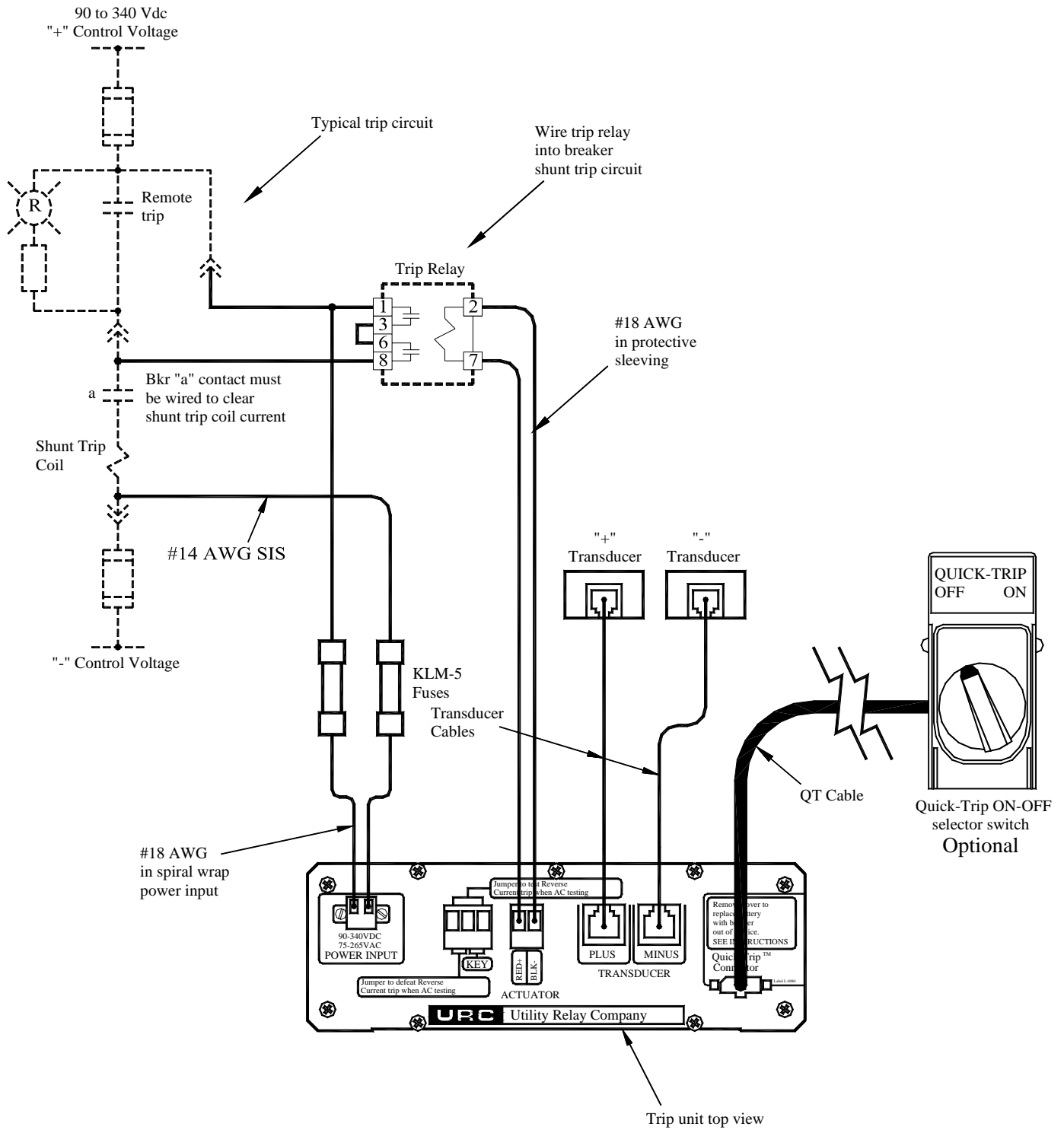

Figure 14.2 Typical Wiring Diagram-Using Electro-Mechanical Trip Relay

THIS PAGE INTENTIONALLY LEFT BLANK

IMPORTANT:
Polarity of Solid-State Relay
& Diode must be observed.
Do NOT apply AC voltage.

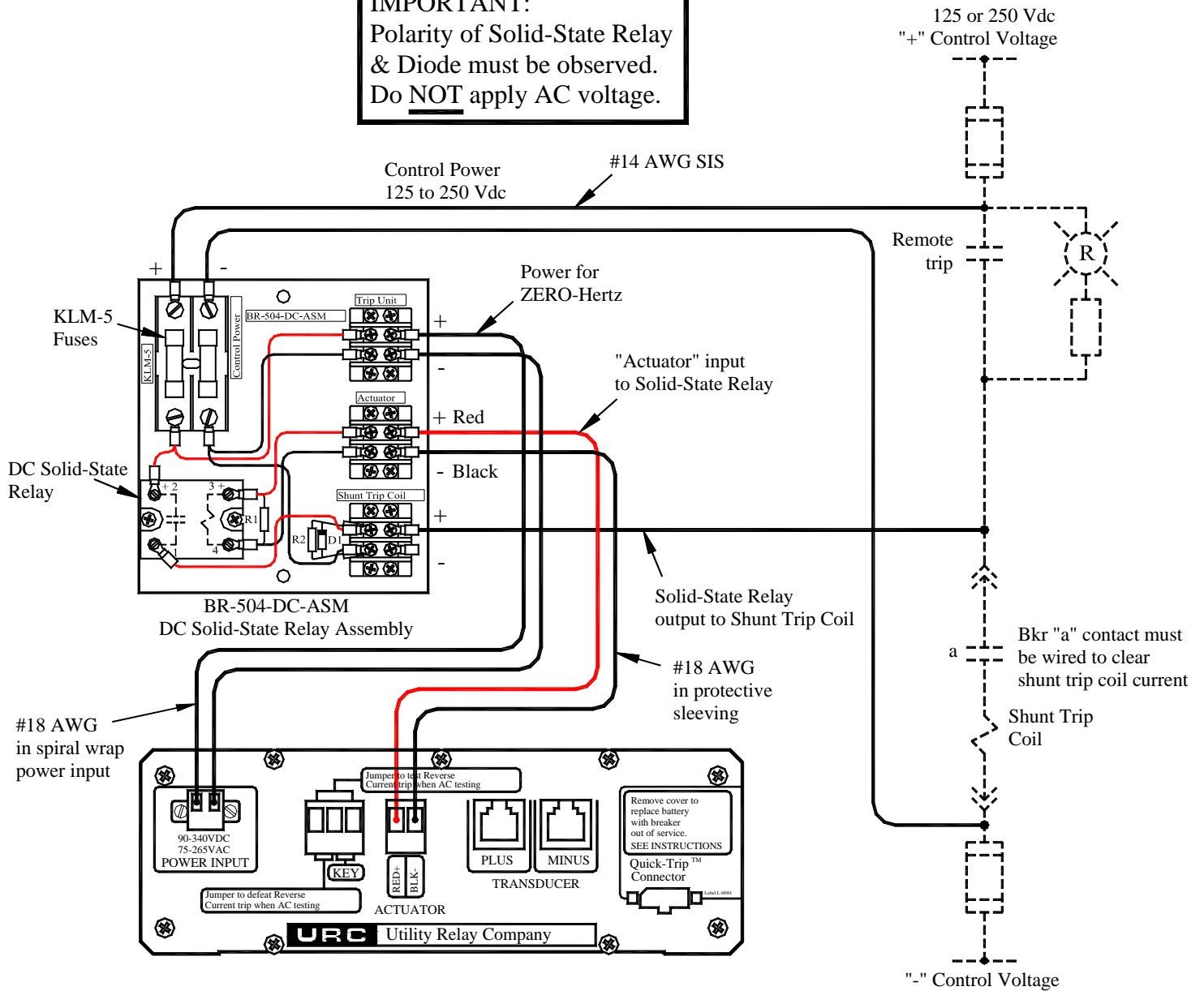

Figure 14.3 Typical Wiring Diagram-Using Solid-State Trip Relay

THIS PAGE INTENTIONALLY LEFT BLANK

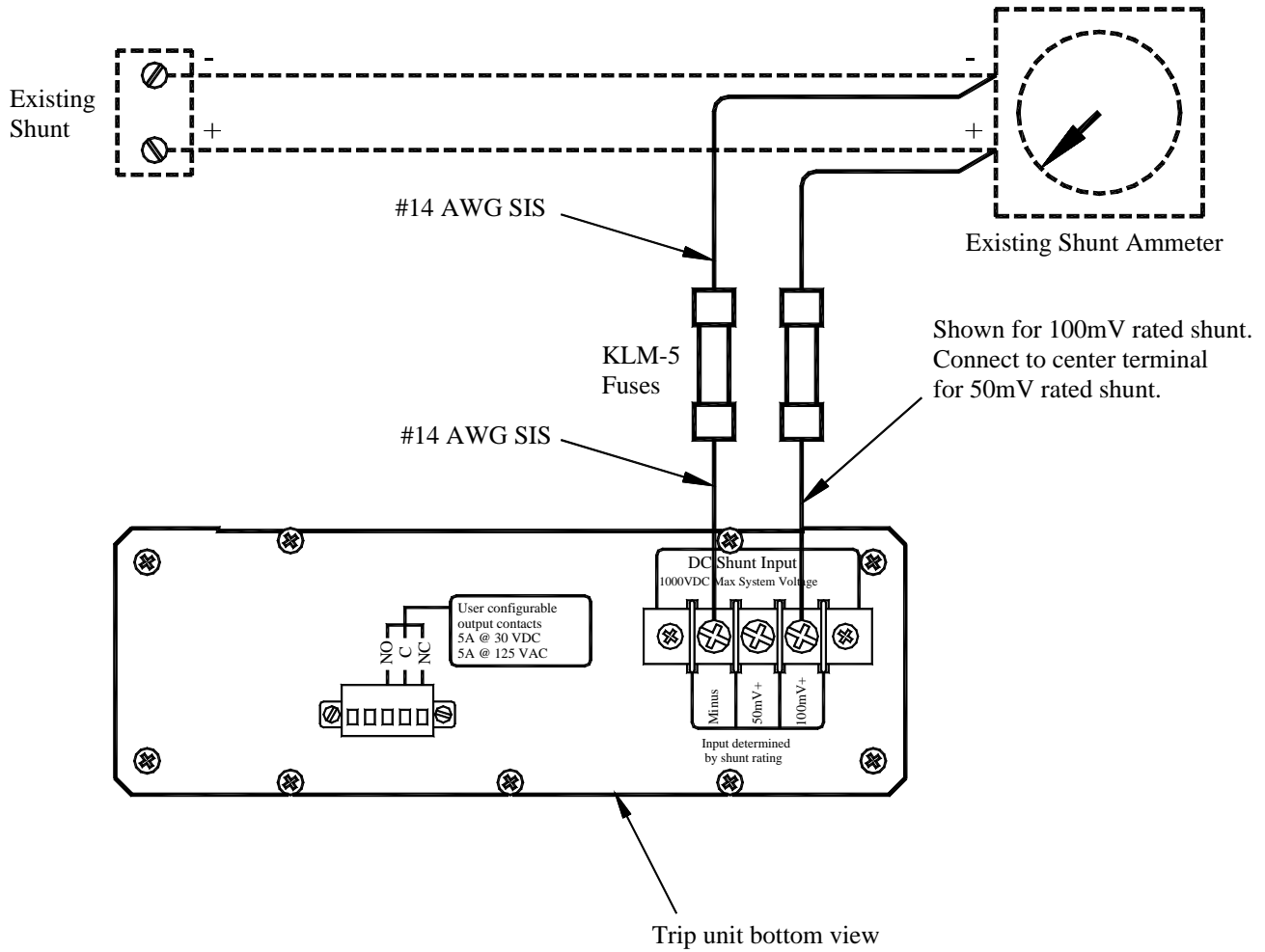

Figure 14.4 Typical Wiring Diagram-Using Shunt Input

THIS PAGE INTENTIONALLY LEFT BLANK

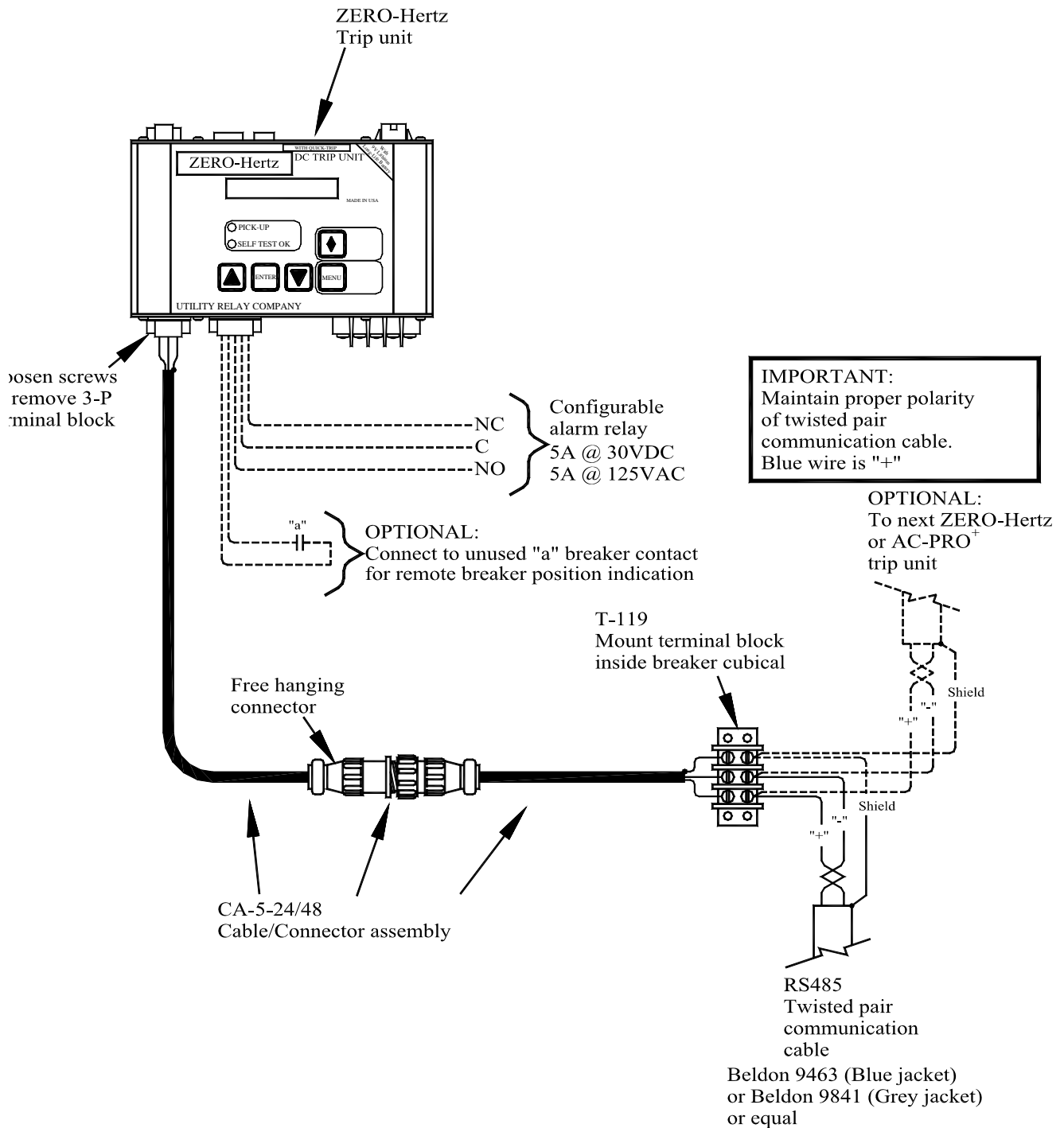

Figure 14.5 Typical Wiring Diagram-Communications Connections

